



Please read and save these instructions. Read carefully before attempting to assemble, install, operate, or maintain the product described. Protect yourself and others by observing all safety information. Failure to comply with instructions could result in personal injury and/or property damage in which Pumptec, Inc. will not assume any liability for! Retain instructions for future reference. Please refer to video links for rebuild tutorials:

[112V Pump Rebuild Tutorial](#)

[217V Pump Rebuild Tutorial](#)



PUMP SERIES 112V | 217V

PERFORMANCE FEATURES

- Long Life
- High-Pressure
- High-Efficiency
- Serviceability
- Durability
- Application Flexibility
- Chemical Compatibility
- Compact Design
- Enhanced Priming



Pumptec pump series 112V | 217V with plunger type design is the most efficient way possible to pressurize water. This efficiency produces up to 20% more pressure or flow for a given power input compared to competitive pumps. The series offers a variety of pump and motor combinations customized to meet specific application requirements. Typical applications include pressure cleaning, pest spraying and misting. All pumps are factory lubricated for long-life performance. The only tool to completely disassemble the pump to its basic components is a hex wrench. Durability and performance results from exclusive use of premium materials. All metallic wetted parts are stainless steel. An aircraft-grade anodized aluminum pump is nearly indestructible compared to pumps made of castings. The body offers chemical compatibility with a wide variety of chemicals. Flow and pressure can be optimized to exactly match power input to nozzle size, and offers an assortment of eccentrics for low, medium, and high pressure to match your application requirement.

UNPACKING

Remove all packing materials. Carefully remove the plunger pumps from the shipping carton. Inspect for any damage that may have occurred during transit. Check for any loose, missing, or damaged parts.

SPECIFICATIONS

Maximum specifications refer to individual performance levels. Maximum performance ratings are maximums and may be conditional on other factors. Consult the Troubleshooting section when operating near any performance maximum. Refer to individual pump data sheets for complete specifications, parts list, and exploded view.

Model 112V

MAX PRESSURE	300 PSI
OPEN FLOW	1.31 GPM
SEALS	V-RING
O-RINGS	BUNA
INLET PORTS (2)	1/4" F NPT
DISCHARGE PORTS (2 OR 3)	1/4" F NPT
MAX FLUID TEMP	TO 140°F

MATERIALS OF CONSTRUCTION

BODY	HARDCOAT ALUMINUM
PLUNGER	STAINLESS STEEL
VALVES	STAINLESS STEEL/ACETAL
FASTENERS	STAINLESS STEEL

Model 217V

MAX PRESSURE	800 PSI
OPEN FLOW	2.2 GPM
SEALS	V-RING
O-RINGS	BUNA
INLET PORTS (2)	1/4" F NPT
DISCHARGE PORTS (2)	1/4" F NPT
MAX FLUID TEMP	TO 140°F

MATERIALS OF CONSTRUCTION

BODY	ANODIZED ALUMINUM
PLUNGER	STAINLESS STEEL
VALVES	STAINLESS STEEL
FASTENERS	STAINLESS STEEL

GENERAL SAFETY INFORMATION

Please read this manual before installing or operating pump to provide safe operation and prevent equipment problems. Observe the following symbols and definitions.

Note: Indicates important instructions which are not related to hazards.

IMPORTANT: Indicates factors concerned with assembly, installation, operation, or maintenance which could result in damage to the machine or equipment if ignored.

CAUTION! *Warns about hazards that MAY cause minor personal injury or property damage if ignored.*

WARNING! *Warns about hazards that COULD cause serious personal injury, death or major property damage if ignored.*

DANGER! *Warns about hazards that WILL cause serious person injury, death or major property damage if ignored.*

PLEASE READ, SAVE AND REFER TO SAFETY INSTRUCTIONS BELOW:

CAUTION! *Pumps build up heat and pressure during operation. Allow time for pumps to cool before handling or servicing. Only qualified personnel should install, operate, and repair pump.*

IMPORTANT: For pumping liquids other than water, contact your supplier.

DANGER! *Do not pump hazardous materials (flammable, caustic, etc.), unless the pump is specifically designed and designated to handle them.*

WARNING! *To reduce risk of electric shock, always disconnect pump from power source before handling or servicing.*

WARNING! *Any wiring of pumps should be performed by a qualified electrician.*

CAUTION! *These pumps are not intended to be submersed.*

Pumptec, Inc. is not responsible for losses, injury, or death resulting from a failure to observe these safety precautions, misuse or abuse of pumps or equipment.



INSTALLATION

MOUNTING

Pump-motor set can be mounted in any position EXCEPT with the pump head higher than the motor. To minimize amp draw, noise, and vibration, use appropriate flexible hose to inlets and discharge ports.

LOCATION

CAUTION! *If the pump is used in extremely dirty or humid conditions, it is recommended pump be enclosed. Do not store or operate in excessively high temperature areas or without proper ventilation.*

The pumping system can be mounted where it is visible, but it must be protected from rain, dirt and chemical spray or splashing. The pump must never be installed on a vertical surface with the pump head higher than motor, like a capital letter "T" for example.

PRE-OPERATION

INLET CONDITIONS

CAUTION! *DO NOT STARVE THE PUMP OR RUN DRY. Temperatures above 130°F will require pressurized inlet to avoid cavitation and seal damage.*

DISCHARGE CONDITIONS

Open all valves in system prior to operation to avoid excessive load on motor and system from a pressure spike. Follow the instructions for proper system design. Refer to supplier if assistance is needed.

PRESSURE REGULATION

Verify pressure regulation devices are operating correctly.

NOZZLES

Nozzles create pressure in most systems, and they become larger with use. Larger nozzles decrease system pressure. Verify the quality of nozzles prior to operation.

MOTOR SHAFT ROTATION

CAUTION! *Motor shaft rotation must always be counterclockwise to assure proper function of pump or warranty may be void.*

PUMPED LIQUIDS

Some liquids may require a flush between operations or before storing. For pumping liquids other than water, contact your supplier.

OPERATION

GENERAL OPERATING INFORMATION

Pressure is often created by forcing a volume of fluid (flow) through a specific size hole (nozzle). Additionally, pressure can be created by pumping into a non-expanding chamber. Pressure is measured and stated in PSI – pounds per square inch.

Flow is created based upon the pump displacement and the speed (RPM) of the motor. Pump plunger size affects flow based on the same RPM. The faster the motor speed, the greater the flow. Flow is measured and stated in GPM – gallons per minute.

The pump, driven by a motor or engine, draws fluid through a set of valves into the pumping chamber and the fluid is then forced out of a set of valves to exit the pump. The back-and-forth movement of the plunger in the sealed pumping chamber creates the suction and discharge actions.

Once the fluid has left the pump it must be controlled until it exits the nozzle or reaches the place it needs to go. This control is achieved via the use of system components such as an unloader or a regulating valve. Pumptec's pumps are positive displacement pumps which provide a constant and specific amount of fluid while operating. This volume of fluid must be directed out thru a nozzle or back to a tank because it cannot be stopped completely without creating excessively high pressure and risk of damage to pump, components, property, or person. It is recommended a safety device such as a regulating valve be installed directly on the pump head as protection in case of a failure of another component. Pressure switches can be used to automate pump operation, but they must have a pressure regulating device installed as a safety device.

Fluid can enter a pump either from a filtered tank or a pressurized fluid line.

It is common to use pumps with a tank that is mounted above the pump. Filtration is important to maintain proper function of the pump and system. The extent of filtration may need to be greater based on application such as with misting with ultra-fine nozzles.

INLET CONDITION CHECKLIST

Inadequate inlet conditions can cause serious malfunctions even in the best designed pump. Surprisingly, the simplest of things can go unnoticed to the unfamiliar or untrained eye and can potentially cause severe problems. REVIEW THIS CHECKLIST BEFORE OPERATION OF ANY SYSTEM. Remember, no two systems are alike so there can be no ONE best way to setup a system. All factors must be carefully considered.

INLET SUPPLY should exceed the maximum flow being delivered by the pump to assure proper performance.

- Open inlet shut-off valve and turn on water supply to avoid starving the pump. **DO NOT RUN PUMP DRY.**
- Avoid closed loop systems especially with high temperature, ultra-high pressure, or large flows. Conditions vary with regulating/unloader valve.
- When using an inlet supply reservoir, size it to provide adequate liquid to accommodate the maximum output of the pump, generally a minimum of 6-10 times the GPM. However, a combination of system factors can change this requirement.

INLET LINE SIZE should be adequate to avoid starving the pump.

- Line size must be a minimum of one size larger than the pump inlet fitting. Avoid tees, 90-degree elbows or valves in the inlet line of the pump to reduce the risk of flow restriction and cavitation.
- The line **MUST** be a FLEXIBLE hose, NOT a rigid pipe, and reinforced on SUCTION systems to avoid collapsing.
- The simpler the inlet plumbing the less the potential for problems. Keep the length to a minimum, the number of elbows and joints to a minimum (ideally no elbows) and the inlet accessories to a minimum.
- Use pipe sealant to assure airtight, positive sealing pipe joints.

INLET PRESSURE should fall within the specifications of the pump.

- High RPM, high temperatures, low vapor pressures or high viscosity may increase the acceleration liquid loss.
- Optimum pump performance is obtained with +20 PSI (1.4 BAR) inlet pressure. With adequate inlet plumbing, most pumps will perform with flooded suction.
- After prolonged storage, pump should be purged of air to facilitate priming. Disconnect the discharge port to allow liquid to pass through pump and measure flow.

BYPASS TO INLET Exercise care when deciding the method of bypass from control valves. See Misting on page 5.

- It is recommended that the bypass be directed to a baffled reservoir tank, with at least one baffle between the bypass line and the inlet line to the pump.
- Although not recommended, bypass liquid may be returned to the inlet line of the pump if the system is properly designed to protect your pump.
- A low-pressure, flexible hose should be used from the bypass connection to the inlet of the pump.
- Caution should be exercised to avoid under sizing the bypass hose diameter and length.
- Check pressure in the bypass line to avoid over-pressurizing.

USING CHEMICALS

Chemicals can be mixed into the fluid, and it is necessary to understand whether these chemicals will damage the pump or other system components. Another way to put chemicals into the fluid is with a downstream injector.

An injector works as the result of a difference of pressure between the inlet side of injector and discharge side. In most cases, the pressure on the discharge side cannot exceed 1/2 of the inlet pressure. For example, 1000 PSI into an injector should allow up to 500-600 PSI spray pressure on discharge side. There are dual-function nozzles that permit high pressure-chemical free rinse and low pressure-chemical spray. These are convenient for the operator and will not harm a properly designed system.

The advantages of an injector are:

- Fewer items touching chemical.
- Chemical injection rate can be controlled.
- Applying chemical at lower pressure increases chemical use efficiency.

HEATING FLUID

The pumps may sometimes be used with downstream heaters and precautions need to be taken to protect the system and persons from harm. Refer to the skilled staff at the equipment manufacturer for guidance and proper system care. Please be aware that heated water expands. Additional pressure release safety devices may be required.

SYSTEM DESIGN

A pump is the heart of every system and proper selection is critical to equipment function and durability. If a pumping set with excess flow is chosen, then energy and fluid is wasted. Equipment effectiveness can decrease if excess pressure results, and so can pump life.

TYPICAL APPLICATIONS AND THEIR PERFORMANCE CONSIDERATIONS

PRESSURE CLEANING

The optimal combination of PSI and GPM for cleaning is a ratio of 1 GPM for every 300-400 PSI. This combination maintains sufficient droplet size for cleaning force and distance. If pressure increases, and flow does not, then the water droplet size reduces and has less impact force, requiring closer cleaning distances and increased risk of surface damage.

PEST SPRAYING

This application can have specific chemical usage requirements

and pressure limits, so use the included information as a guide only. Refer to label requirements for each specific chemical.

LINE LOSS

When choosing a pump for spraying, pressure loss, or line loss, in the hose must be considered. The pressure is greatest at pump and decreases over the length of the hose. Typically, these systems utilize very long hoses, 200-300 ft. is common, and requires a certain minimum amount of performance to move the flow through the lengths of hose. For example, a 3 GPM system will require (lose) 50 PSI per 50 ft. of 3/8" ID hose. A pump with only 60-70 PSI may not provide the desired performance at the end of the hose. See reference charts to assist in system design.

MISTING

It is critical to size the pump correctly in a misting application. If insufficient flow is chosen, then proper atomization and droplet size will not result. If excessive flow is chosen, then unnecessary wear and wasted energy will occur in this very demanding application.

Another consideration for misting concerns the routing of the bypass fluid. DO NOT return bypass fluid from regulating valve directly back to inlet of pump. The returned fluid will contain large amounts of air bubbles that will cause cavitation and damage within the pump head. Also, the small amount of returned fluid can heat up rapidly and lead to further cavitation and component damage. It is recommended to route bypass lines through a filter to allow air bubbles to dissolve and water to cool prior to entering the pump.

NOTE: Nozzle sizes in the performance chart are additive. For example, two pieces of '02 nozzle equals the performance of one '04 nozzle piece when creating restriction (pressure) in the system. If unsure of the nozzle size needed for desired performance, refer to the Nozzle Performance Chart. If you are sure of your nozzle size, but unsure of which pump set to choose, then use the Nozzle Performance Chart along with the Horsepower Chart on our website to determine your required pump specifications. Here is an example of how to use these charts together: when you have two pieces of an '02 nozzle and you want 500 PSI, the nozzle chart will tell you that two pieces of an '02 nozzle has a flow equal to one piece of an '04 nozzle. At 500 PSI, an '04 nozzle has a flow of 1.4 GPM. The performance specification is 1.4 GPM at 500 PSI.

STORING

For extended storing, or between uses in cold climates, drain all pumped liquids from pump and flush with antifreeze solution to prevent freezing and damage to the pump. DO NOT RUN PUMP WITH FROZEN LIQUID.

NOTE: Each system's maintenance cycle will be unique. If the system performance decreases, investigate it immediately. If no wear at 500 hours, check again at 1000 hours and each 500 hours until wear is observed. Valves typically require changing at every seal change. Duty cycle, temperature, quality of pumped liquid and inlet feed conditions all affect the life of a pump's parts and service cycle.

NOTE: Remember to service the regulator/unloader at each seal servicing. Check all system accessories and connections before resuming operation.

NOZZLE PERFORMANCE CHART FLOW RATE VS. PRESSURE

GPM (GALLONS PER MINUTE) @ PSI (POUNDS PER SQUARE INCH)							
SS TIP #	60	80	100	200	300	400	500
2	0.25	0.28	0.32	0.45	0.55	0.64	0.71
3	0.37	0.42	0.47	0.67	0.82	0.96	1.10
4	0.49	0.57	0.63	0.89	1.10	1.26	1.40
6	0.73	0.85	0.95	1.34	1.64	1.90	2.10
8	0.98	1.13	1.26	1.79	2.20	2.52	2.80
10	1.22	1.41	1.58	2.24	2.74	3.16	3.50
12	1.47	1.70	1.90	2.68	3.29	3.79	4.24
15	1.84	2.12	2.37	3.35	4.11	4.74	5.30
20	2.45	2.83	3.16	4.47	5.48	6.32	7.07
30	3.67	4.24	4.74	6.71	8.22	9.49	10.61

MAINTENANCE

DISASSEMBLY AND REASSEMBLY
INSTRUCTIONS ([112V VIDEO](#)/[217V VIDEO](#))

1. Remove pump from motor using a 3/16" hex wrench. Remove bolts from pump. Turn pump over so manifold is facing upward.

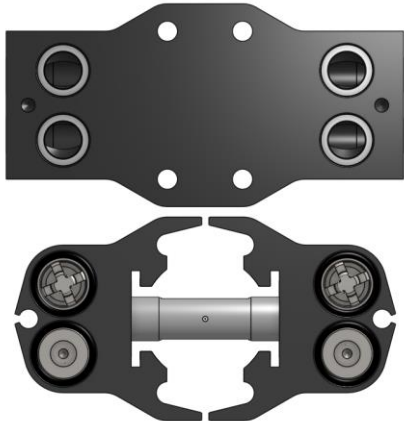

Figure 1

2. Holding each head, pull them apart to remove plunger. Remove retaining plate from pump head. Remove internal seal parts with finger. Discard parts but keep head and retaining plate.

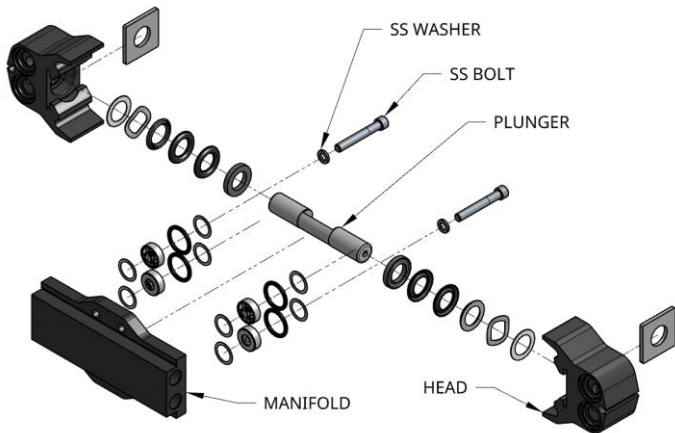

Figure 2

3. Clean the head with a rag or towel. Inspect for damage or excess corrosion. If the head is damaged, do not rebuild. Note the order and orientation of repair parts prior to installation. See video or Fig. 3 for order and orientation.
4. Place one insulating washer, one wave washer, one spreader and two v-rings into bore.

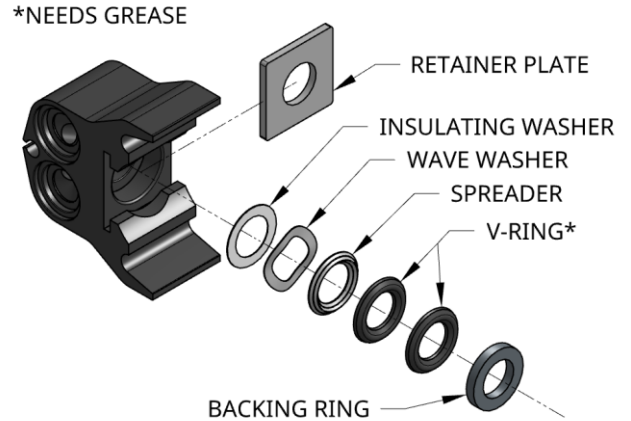

Figure 3

5. Place backing ring on top of v-rings. The backing ring will need to be pressed down to be even with the opening on the head so the retaining plate can slide into place. If uneven, reposition stack and try again.

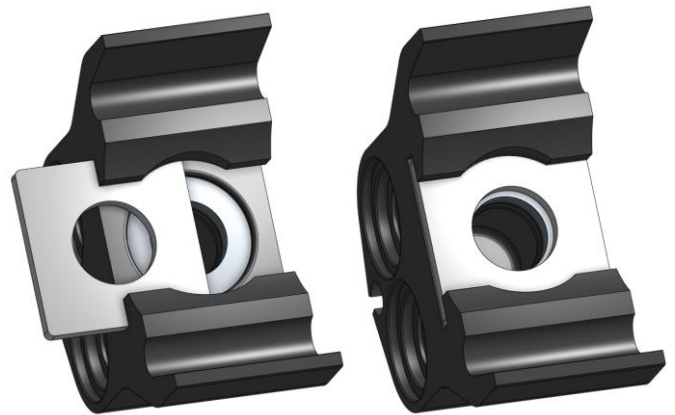

Figure 4

6. Repeat the previous steps 3-5 with the other head.
7. Lightly grease the plunger with the clear grease provided in small grey tube. Slide plunger into one head assembly and then slide the other head onto plunger. Place head and plunger assembly on work surface with valves facing upward.

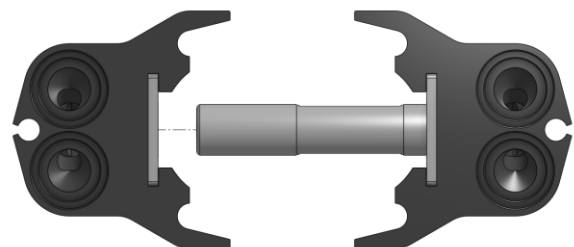

Figure 5

- Adjust plunger slot position towards center and have slot facing work surface. Replace all valves, o-rings, and white washers. Refer to Fig. 6 or 7 or video for proper orientation.

IMPORTANT: It is imperative the alignment of OUT/IN ports coincide with valves as indicated in Figure 7.

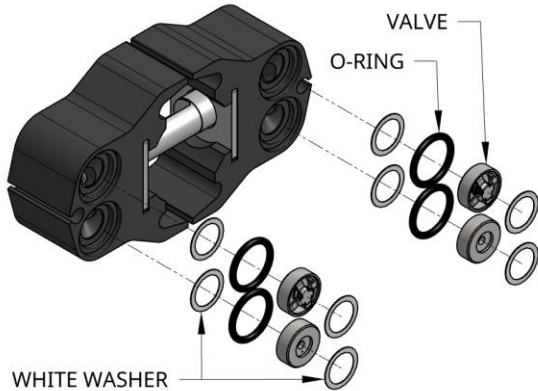

Figure 6

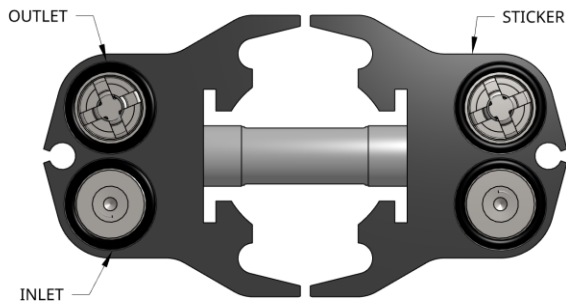

Figure 7

- Place manifold on top of heads. It may be necessary to move heads around on plunger to have valves align with valve pockets on manifold. Be careful not to lose the white washers on the manifold during reassembly. You may hear a click when everything is aligned.

- Turn assembly over and place shorter bolts and washer assembly into heads. Tighten finger tight. DO NOT tighten completely at this time.

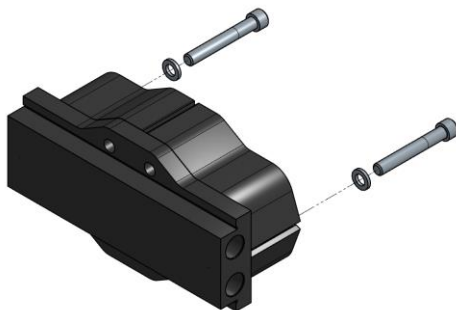

Figure 8

- Apply **Super lube® multi-purpose grease** from supplied packet into corners and center of plunger slot.

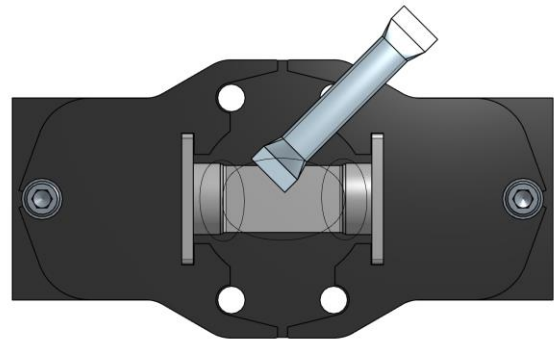

Figure 9

- Mount pump back onto motor and tighten mounting bolts to 14 in/lbs. of torque. Tighten head bolts to 14 in/lbs. of torque.

PREVENTATIVE MAINTENANCE CHECKLIST

Check	Daily	Weekly	50 Hrs.	500 Hrs.	1500 Hrs.	3000 Hrs.
Clean Filters	X					
Water Leaks	X					
Descale Pump		X	X			
Cam & Bearing				X	X	
Seal Change				X	X	
Valve Change				X		X

TROUBLESHOOTING CHART

SYMPTOM	POSSIBLE CAUSE(S)	CORRECTIVE ACTION
No water flow	<ol style="list-style-type: none"> 1. Tank is empty or water is not turned on 2. Filter clogged 3. Pump valves clogged or damaged 4. Pump has lost prime 	<ol style="list-style-type: none"> 1. Fill tank or turn on water supply 2. Clean filter 3. Examine valves and clean or replace 4. Follow priming procedure
Low pressure	<ol style="list-style-type: none"> 1. Worn nozzle 2. Leak in high pressure hose or connections 3. Filter clogged 4. Pump valves clogged or damaged 	<ol style="list-style-type: none"> 1. Replace nozzle with new one of same size 2. Check hose and connections 3. Clean filter 4. Examine valves and clean or replace
Pump pulsates when spraying	<ol style="list-style-type: none"> 1. Filter clogged 2. Pump valves clogged or damaged 	<ol style="list-style-type: none"> 1. Clean filter 2. Examine valves and clean or replace
Motor does not operate	<ol style="list-style-type: none"> 1. Blown fuse or circuit breaker 	<ol style="list-style-type: none"> 1. Replace circuit breaker or fuse. Check circuit for wire damage or component damage
Leaks seen under pump	<ol style="list-style-type: none"> 1. Worn pump seals 2. Abrasives in solution have damaged pump seals 	<ol style="list-style-type: none"> 1. Replace with new plunger and seals 2. Mix chemical thoroughly and improve filter
Regulator leaks fluid from cap	<ol style="list-style-type: none"> 1. Pressure is set too low 	<ol style="list-style-type: none"> 1. Set pressure higher to keep internals from moving too much 2. Replace seal

For Repair Parts, call 763-433-0303

Please provide following information:

- Model number
- Serial number (if any)
- Part description and number as shown in parts list



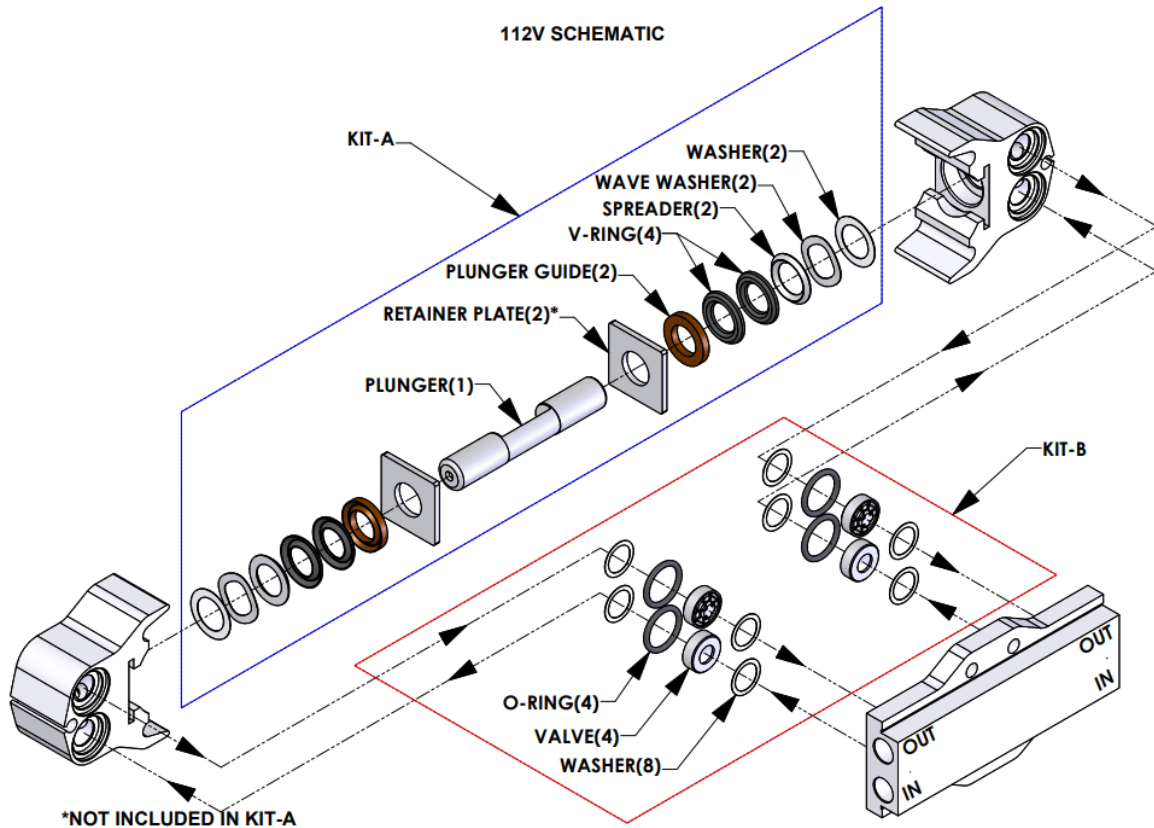

Repair Parts Illustration for Plunger Pump
 Note: 217V internal components are the same as 112V internal components

REPAIR PARTS LIST FOR PLUNGER PUMP

DESCRIPTION	PART NO.	QTY	DESCRIPTION	PART NO.	QTY
KIT A, 112V	10009		KIT B	10004	
KIT A, 217V	10031		White Washer, ½" ID	^	8
Plunger	^	1	O-Ring, 1-116	^	4
Backing Ring	^	2	Valve Assembly	^	4
V-Ring	^	4	Retainer Plate	*	2
Spreader	^	2	Pump Head	*	2
Wave Washer	^	2	Pump Manifold	*	1
White Washer, 5/8" ID	^	2			

(^) Sold only as part of a kit. | (*) Not part of a kit, for identification only.

ADDITIONAL RESOURCES

[Pumptec Returns Authorization Request Form](#)

[Warranty Policy](#)

Prompt Disposition A good faith effort will be made for prompt correction or other adjustment with respect to any product which proves to be defective within limited warranty. For any product believed to be defective within limited warranty, first visit Pumptec's website, email, or call Pumptec. Pumptec will give additional directions. If unable to resolve satisfactorily, write to Pumptec at the address below, giving the serial number, invoice number and date, and describing the nature of the defect. Title and risk of loss pass to buyer on delivery to common carrier. If product was damaged in transit to you, file claim with carrier.

Manufactured by Pumptec, Inc. 700 McKinley St. NW, Anoka, Minnesota 55303 U.S.A.

Phone: 763-433-0303